



## Experimental Aircraft Association

### CHAPTER 393

#### Concord, California

PRESIDENT

Dick White, Sr.  
415/837-2874

SECRETARY/TREASURER

Rich Powell  
415/229-1281

AIRPORT LIAISON

Virginia Schaefer  
415/687-2809

COFFEE HOST

Louis Goodell  
415/682-4198

VP - RAE & ?

Kay Smith  
415/825-4211

CHAPTER MEETING: Wednesday, February 27, 1985 at 7:30 p.m.  
Buchanan Field Terminal Building - EVERYONE IS WELCOME!!!!

Our program for the February meeting is a discussion on Formation Flying by Carlos Ampoker...somewhere along the line he has acquired a great deal of experience in formation flying, participation in which can ruin your entire day if you do not know vast amounts about what you and whomever you are flying with are doing. Carlos also has bunches of experience as a speaker - how about four years as President of this Chapter, and he is very entertaining along with informative.

Also on our program for the evening is a presentation on the infamous Biennial Flight Review by member and world renowned glass airplane builder, Dr. Lou Ellis (a closet CFI!). I know a number of you have questions about the value of the BFR, including its value and what it SHOULD cover. Lou is

the man who knows his way around the BFR. It is certain to be an interesting and educational presentation/discussion.

A note for those attending any chapter meeting: please bring something to plant yourself on. Those who attend regularly are aware that there are not enough chairs, but it pains your editor to see a dozen or more people standing thru' each meeting.

Please note also, that a current copy of the roster will be available to all those who wish one, on the front table at the February meeting. If you can not attend and would like a roster, send a SASE (with extra postage) to EAA #393, P. O. Box 2269, Walnut Creek, CA 94595 and we'll get one to you.

Reminder to those who have received chapter dues billings....if you forget us, after 90 days you cease to exist! As far as the roster goes, it is updated every 30 days and you vanish into thin air.....I can't imagine anyone intentionally missing this 'delightful' tome.....so fork over the loot!

Experimental Aircraft Association  
Chapter #393  
P. O. Box 2269  
Walnut Creek, CA 94595

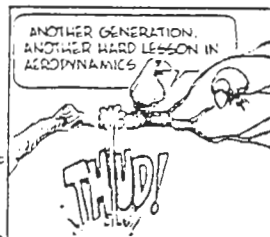

# EAA



# EAA CHAPTER

NUMBER 393 OF Concord ZIP \_\_\_\_\_

● A LOCAL CHAPTER OF THE EXPERIMENTAL AIRCRAFT ASSOCIATION, INC. ●

## GENERAL MEETING Jan. 23, 1985

Club president, Dick White, Sr., opened the meeting at 7:40 and welcomed one and all. There were 57 attending. Dick covered some mail items, several ads, literature on the front table, passed out some membership cards, etc. None of the member-representatives from California Aviation Council or the Airport Advisory Committee were present to give a report. Bob Graves had a short report about the Airport Building Project - it seems there is a problem in that our EAA chapter, although non-profit, is not a charitable, tax exempt organization. This means any corporation or group wanting to donate construction or operation funds would not be able to deduct the amount from taxes and so would not have much incentive to make a contribution. There are several people looking into this. One possible way to fund both construction loan and operational expenses is to sell auto-gas. Dick White reported that there has been good response to the Primary Aircraft Proposal - 800 positive to only 25 negative comments. Our chapter sent a positive comment in support of the proposal. Dick also spoke briefly about the EAA Academy - a course during the summer designed to give youngsters an experience building an aircraft. Dick ran through the calendar for the year, looking for chairpeople to lead up some of the monthly programs, especially the annual picnic (Dwain Duis) and the Pope Valley Fly-in (Rick Kelley & Randy Alley?). Bob Gonzales announced the possibility of a fly-in to Travis Air Museum - a list of interested people was collected - if you weren't at the meeting and want to be contacted, call Rich Powell (229-1281) or Kay Smith (825-4211) to add your name. Introductions around the room followed. Our speaker that was to present a program on the Flying Wing came down with a case of the flu that's going around - a lot of disappointed faces. We had a Confederate Air Force movie instead, and hope to reschedule Wing program.

Rich Powell, Secretary

THE PRESIDENTS MESSAGE

The weather is already getting better and it will soon be time to roll out your airplane and get a good jump on spring flying. We should be hearing about some first flights soon, too.

This years chapter activities are starting out with a harbinger of good things to come. I was most pleased with the response to the request for volunteers and participation in the coming chapter events. If you will note the calendar of events in this Newsletter, happily we have a full agenda of chapter meeting programs, complete with chairpersons! Also, we have leaders and organizers now for most all of the activities planned for the new year. Now, all we need is when the chairperson asks for some help - lets give it to them.

Thanks,  
Dick White, President

---

FOR SALE \*\* WANTED \*\* LUSTED AFTER \*\* THE WIFE SEZ I GOTTA' GET RID OF \*\* GIMME ONE

FOR SALE: Marvel Scheibler HA6 Carburetor - side draft - 40 hours since new -  
Call Prez. Dick White (415) 837-2874

FOR SALE: Cessna 152 wings - very minor damage - as is \$1,000 - repaired \$1,500 -  
Call Bob O'Grady (415) 938-7620

FOR SALE: Quicksilver Ultralight - with tricycle & floats - call Pete Wiebens -  
(415) 933-7517 or 687-0937

FOR SALE: Q-2 partially completed - Call Don/Peggy Beasley (415) 432-9139

FOR RENT: Part of a small hangar/shop - call Rick Lambert (415) 689-3168

WANTED: Continental A-65 for Aeronca KCA - call Bette Davis (415) 881-8118 days.

FOR SALE: Low time Tomahawk - \$5,000 - call Navajo Aviation (415) 685-1150

FOR SALE: Aircraft trailer - call Bob Gonzales (415) 798-5100

FOR SALE: Quickie kit - still in the box with 18 hp Onan engine - call Jan Switalski (415) 228-6399

FOR RENT: East ramp tiedown between hangars D and E - available for appx. 3 months - Call Larry Laughlin (415) 758-3532

NOTE: If you have something you'd like to sell, give away, find or whatever (as long as it isn't of a commercial nature), let any officer know by the second Wednesday of each month and we'll run your ad. Also, how about letting someone know when you no longer need the ad? As it is now, they run for three months and vanish.....

\*\*\*\*\*

Chapter #393 owns the Oshkosh Video - Rich Powell is the keeper of the tape and it is available for your use for \$1 per day or \$2 per weekend. The tape will be kept at Rich's office: Hilltop Optical, 1855 San Miguel Drive, Walnut Creek. Call Rich at 935-8822 during business hours if you would like to rent this outstanding tape.

SPY IN THE SKY - Sees ALL - Knows ALL - Tells SOME!

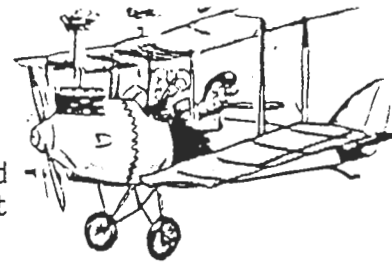

Those of you who have little knowledge of the homebuilder trying to certify an aircraft, read on. It seems that a homebuilder wanted to design, build and certify an aircraft. He gave the FAA/DOT a set of specifications and a deadline for testing the new craft.

After months of effort, the day came to send up a test pilot to try it out. Everything went fine until the dive. At a critical point, both wings failed, the test pilot bailed out and it was back to the drawing board. Plane #2 was built with extra strong wings, by a now very nervous builder. The great day arrived and the test pilot took her up - the same thing happened. Again, both wings failed in the dive and tore off.

The builder was really rushed as the deadline fast approached. With the test pilot ready for the following day, the builder was very upset as he hadn't found the reason for the failures. As he stood shaking in his boots, the janitor (all hangars have janitors!) walked in and asked what was wrong. The builder said his creative days would be over if the wings failed again....the janitor said he would think about it overnight. The builder laughed.....

The next morning the janitor was back with a suggestion: drill a row of tiny holes all the way across the wing, leading to trailing edge, top and bottom. Not having come up with anything, the builder decided to try it.

At the appointed time, the test pilot went up and the bird flew beautifully - everything was perfect. To the elation of the builder, when the dive was repeated, the wings held! Finally, someone thought to ask the janitor if he was an engineer or scientist and how he had come up with the solution. "Nothing like that" was his reply. "I was sitting in the bathroom last night and I suddenly realized that the paper never tears where they put the little holes."

Happy CAVU to you, too!

DICK RUTAN  
JEANA YEAGER

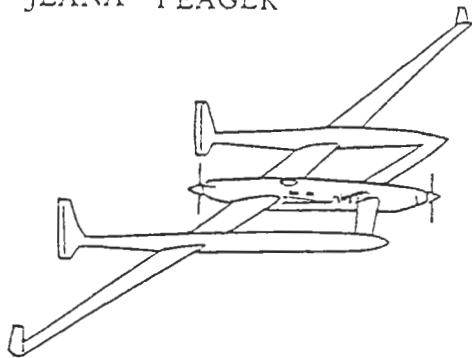

AROUND THE WORLD  
NON-STOP NON-REFUEL  
VOYAGER

MARCH 1, 1985

Presented by:  
CAFE 400 FOUNDATION

SANTA ROSA VETERANS  
MEMORIAL BUILDING

info. 874-3078

7:30 PM

LECTURE TO BENEFIT THE VOYAGER PROJECT

HOW TO MEASURE SMALL ANGLES WITHOUT

A PROTRACTOR OR TRIGONOMETRIC FUNCTIONS (SIN, TANGENT, ETC)

RADIANS A MEASURE OF ANGLE BY RADIANS LENGTH OF ARC  
LENGTH OF RADIUS

1 RADIAN = 57.29577951... OR ABOUT 57.3°  
(AS NEAR AS MY CALCULATOR  
WILL GO. IT DOES ROUND OFF)

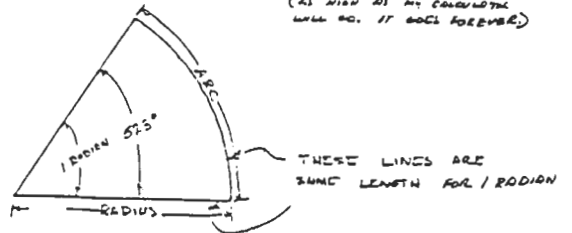

EXAMPLE  
FOR AN INCIDENCE OF 5° ON A WING WITH 60" CHORD

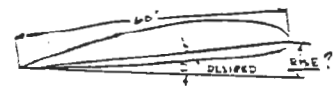

$$\text{RISE} = 5^\circ \times \frac{1 \text{ RADIUS}}{57.3^\circ} \times 60''$$

ARC LENGTH = ANGLE / RADIUS

RISE = 5.24 INCHES

FOR A 10° ANGLE THE DIFFERENCE WORKS OUT TO 0.05 INCH (ABOUT 1/20"), NOT TOO GOOD, BUT BETTER THAN USING A PROTRACTOR

BY MORE EXACT SIN FUNCTION

$$\text{RISE} = \sin 5^\circ (60'')$$

$$\text{RISE} = 5.23 \text{ INCHES}$$

DIFFERENCE 0.01 INCH VERY CLOSE

B.C.

EXPERIMENTAL AIRCRAFT ASSOCIATION

CHAPTER #393

1985  
CALENDAR

BOARD OF DIRECTORS

2nd Wednesday of every month -  
President Dick White's home  
301 David Drive, Alamo  
All members welcome - 7:30 p.m.

CHAPTER MEETINGS

4th Wednesday of every month - 7:30 p.m.  
Buchanan Field Terminal Building  
Bring chairs - Bring chairs - Bring chairs!  
EVERYONE is Welcome

FEBRUARY

Chapter: February 27th - Carlos Amspoker on Formation Flying (Demos' Revenge!) and Lou Ellis on the Biennial Flight Review.

MARCH

Board: March 13th  
Chapter: March 27th - George Perreira on his designs: the Osprey and GP-4.

APRIL

Board: April 10th  
Chapter: April 24th - Tim Roberts on Safety and Health Hazards of Homebuilding.  
Activities: Shafter Warbirds in Action, Fly-in/Airshow, April 27-28.

MAY

Board: May 8th  
Chapter: Pope Valley Fly-in! Chairpilots are Rich Kelley, Rob Cook and (quite possibly a surprise) Randy Alley. Scheduled June 1-2 ?????  
Activities: Columbia Luscombe Fly-in - May 17-19  
Nut Tree Swap Meet - May 19  
Watsonville Fly-in/Airshow - May 24-26

JUNE

Board: June 12th  
Chapter: June 26th - Oshkosh 1984 Video.  
Activities: Merced Fly-in/Airshow - June 7-9 - THE BEST IN THE WEST!  
Columbia Fly-in - June 15-16 - a laid back good time.  
CAFE 400 - June 21-22 - The FASTEST in the west.  
Truckee Fly-in/Good Guys Airshow - June 22-23 - 'party time'.

JULY

Board: July 10th  
Chapter: PRE-OSHKOSH PICNIC - JULY 17th (one week early) - Sasha has again volunteered to Chairpilot the bash and Dwain promises to assist...with a team like that, we can't loose! We need AT LEAST 5 chili cookers so we don't run out AGAIN - please call Sasha or Dwain. Also, for a little extra 'entertainment', the 'SPY' tells me that Norm Spitzer has promised to groundloop his Glasair.....  
Activities: Hollister Fly-in - July ? (anyone know when?)  
OSHKOSH - July 26 through August 2 - if you have not made your pilgrimage to MECCA, this is a MUST! Some of us have little chance anyway, but you will never make it to Heaven if you have not been to Mecca first - this IS Heaven!!!!

1985 Calendar - continued

AUGUST

Board: August 14th

Chapter: August 28th - Fred Harris on the flying wing - moved from January as Fred had the bug.

Activities: Abbotsford B.C. Airshow - August 9-11

Cloverdale Fly-in - August 17-18

Georgetown Superchicken Fly-in - August 31 - September 1

SEPTEMBER

Board: September 11th

Chapter: September 25th - \*\*SEE BELOW\*\*

Activities: Reno Air Races - September 12-15

OCTOBER

Board: October 9th

Chapter: October 23rd - \*\*SEE BELOW\*\*

Activities: Rio Vista Fly-in???? October 5-6????

NOVEMBER

Board: November 13th

Chapter: November 27th - \*\* SEE BELOW\*\*

DECEMBER

Board: December 11th

Chapter: CHRISTMAS DINNER/AWARDS BANQUET - Friday, December 13, 1985 - Concord Elks Club - Rich Powell and Kay Smith are Co-chairpilots.

- 
- \* Program notes for the empty spaces: John McCombs has volunteered to contact the\*\*
  - \* Walnut Creek attorney who flew an ultralight coast to coast! Rich Powell is \*\*
  - \* going to contact Heidi, the Napa lady who, on a trans-Pacific ferry flight, \*\*
  - \* ditched a 182 and was picked up by the Russians! Carlos is going to ask \*\*
  - \* our Aerodrome manager to fill us in on plans for our nest. Sounds like we \*\*
  - \* will soon be able to fill some of the holes in our program schedule with some \*\*
  - \* VERY interesting and exciting speakers. I don't know about you but I'd have \*\*
  - \* myself locked up if I ever considered flying an ultralight coast to coast, \*\*
  - \* let alone a 182 across the big mud puddle! \*\*
- 

Re: the power of the press - I guess someone out there really does read this here literary masterpiece! Your editor moaned, groaned, griped and complained about the terrible condition of the access road to the Northwest Ramp.....probably a coincidence but some invisible benefactor has filled in the worst of the challenges to the Grand Canyon.....MANY, MANY, MANY THANKS!

A note regarding the 'Old Fogey' comments I neglected to edit from the SPY's contribution (?) to our newsletter last month: by the calendar, I am probably among the 'senior' half (age wise) of this group and I'll be \*@#%±\*& if I'll sit home and watch my arteries harden! A large number of those who are doing just that - sitting home and missing all the fun - are UNDER 30. The SPY may be a little spicy in 'its' comments regarding missed opportunities to join the crowd and enjoy a good time - - - I just feel sorry for those who by choice, miss out. You only go around once.....'Grab a little Gusto' while you can!